

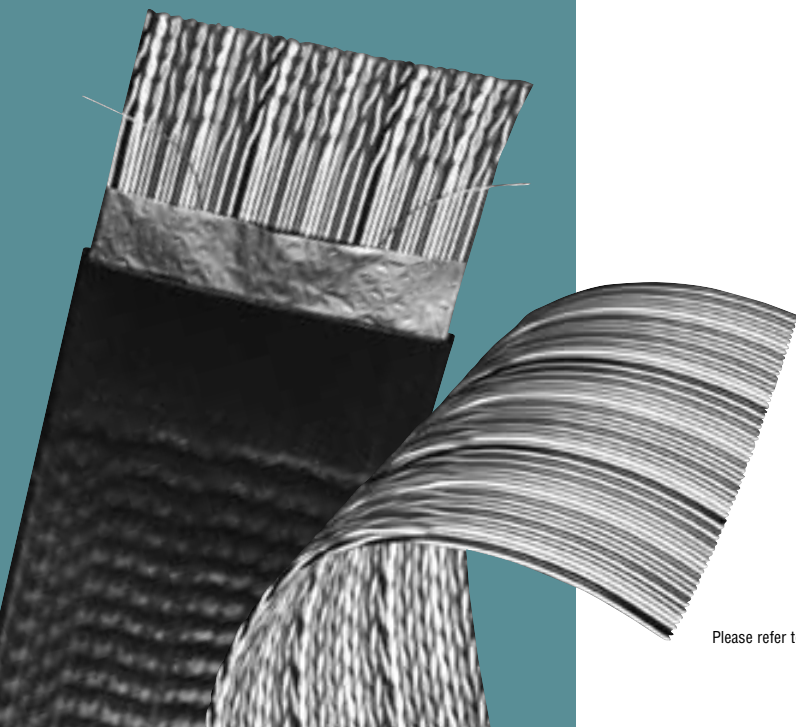

## Table of Contents

<b>Flat Cable</b>	<b>Page No.</b>
<b>Introduction</b>	<b>7.2</b>
<b>Gray Ribbon</b>	<b>7.3–7.6</b>
9L300XX Series: .025" Pitch, 30 AWG, PVC	7.3
2L280XX Series: 1mm Pitch, 28 AWG, PVC	7.4
9L280XX Series: .050" Pitch, 28 AWG, PVC	7.5
9L260XX Series: .050" Pitch, 26 AWG, PVC	7.6
MIL-C-49055/1: .050" Pitch, 28 or 26 AWG, PVC	7.5–7.6
<b>Rainbow</b>	<b>7.7–7.8</b>
9R280XX Series: .050" Pitch, 28 AWG, Color-coded PVC	7.7
8R280XX Series: .050" Pitch, 28 AWG, Color-coded FEP	7.8
<b>Vari-Twist®</b>	<b>7.9–7.10</b>
9V280XX Series: .050" Pitch, 28 AWG, PVC	7.9
8V280XX Series: .050" Pitch, 28 AWG, FEP	7.10
<b>Shielded Jacketed</b>	<b>7.11</b>
9L283XX Series: .050" Pitch, 28 AWG, PVC	7.11
<b>Shielded Jacketed Vari-Twist</b>	<b>7.12</b>
9V283XX Series: .050" Pitch, 28 AWG, PVC	7.12
<b>Technical Information</b>	<b>7.13</b>



## Introduction

Belden® flat cables are designed using the same expertise and design sophistication that made Belden a leader in round cable. Whatever your application, Belden is committed to offering quality flat cable products at a competitive price. Our extensive line includes Gray Ribbon, Rainbow, Vari-Twist® and Shielded and Jacketed Flat Cable options. Many of these are available off the shelf from local distributors. If you have a new or unusual application or you cannot find a flat cable in this catalog section that meets your technical requirements, contact Technical Support at 1-800-BELDEN-1.

### Benefits of Flat Cable

- **Mass Termination** Terminating flat cable is done with the entire group of conductors as a unit, which is more efficient than working with individual conductors at one time.
- **Reliability** The simplicity of flat cable with its parallel conductor geometry eliminates many of the common sources of wiring error and malfunction. Registration of the conductors is one-to-one with the terminating connector or board so that proper contact assignment is almost automatic.
- **Space and Weight Reduction** The use of flat cable often eliminates much of the conventional wire weight and bulk. Such things as redundant insulating materials, fillers and tapes are not required. In addition, the composite flat cable construction is so mechanically strong that it is not necessary to have large conductors for strength. The copper cross-section can thus be reduced to what's required to carry the current load or to satisfy voltage drop requirements.
- **Flexibility** Flat cable is extremely flexible when bent in the plane of its thin cross-section. This flexibility has been utilized in applications where continuous or high flexing is necessary, e.g. drawers, doors, rotating arms, etc.
- **Greater Strength** Strength is enhanced by the fact that all conductors and insulation equally share tensile loads.
- **Consistent Electrical Characteristics** Because the conductor spacing is fixed and the geometry of the cable is constant, the electrical characteristics, such as impedance, capacitance, inductance, time delay, crosstalk and attenuation, are consistent.
- **Greater Current Carrying Capacity** Flat cables have greater surface-to-volume ratio than their round cable counterparts, consequently having higher efficiency in dissipating heat. This allows a higher current level for a given temperature rise and conductor cross-section.
- **Reduced Skewing Effects** Due to the conductors having the exact physical and electrical length, along with a continuous and consistent dielectric, time delays between signals within a given flat cable are minimized.
- **High-Density Interconnections** The cabling density achievable using flat cable is superior to that using conventional cable because of the high wire-to-cable cross-sectional density. Layers of flat cable are more effectively packed for higher conductor density than round cable.
- **Ease of Handling** Flat cable folds and bends readily, conforms to the mounting area, fastens easily with clamps, adhesive, or double-faced tape, and eliminates the installation and lacing difficulties associated with round wire cabling. Visible conductors in a fixed position within the dielectric simplify coding, inspection and circuit tracing.

### Flat Cable Packaging

Packaging of flat cable is offered in one or more of the following configurations, as noted in the Physical Specifications table for each product:

- 100: 100' put-up in a cardboard container. May contain more than one piece.
- H100: A one-piece 100' length, in a cardboard container.
- H300: A one-piece 300' length, in a cardboard container.
- R300: A one-piece 300' length put-up on a reel. It is designed for use by assemblers who use automated terminating equipment. An additional feature is the 9" inner tail exposed through the flange. This enables users to terminate the cable end to a device, which is necessary for in-line testing.

Note: Material on this page obtained from and printed with the permission of the Institute for Interconnecting and Packaging Electronic Circuits (IPC).



# Gray Ribbon 9L300XX Series

.025" Pitch, 30 AWG, PVC

## Product Description

Belden's miniaturized .025" pitch extruded gray ribbon cable provides higher signal density, greater design flexibility, and an alternative to the expensive Teflon® transmission cables. The cable is manufactured to precise tolerances which allows for mass-termination to standard .050" contact IDC connectors while assuring consistent and reliable electrical characteristics. With the miniaturization of the interconnects, significant reduction in components can be achieved. The cable is constructed of stranded 30 AWG (7x38) tinned copper conductors. Insulation material consists of Gray PVC, with a Red polarity stripe for proper circuit alignment. Standard conductor counts are 26 and 50; other sizes are available upon request. The cable is UL approved and CSA certified, and passes the VW-1 Vertical Wire Flame Test.

**Color Code:** Gray with Red polarity stripe.

**Application:** Internal interconnection or internal wiring of electronic equipment.

## Physical Specifications

<b>Conductor</b>	30 AWG (7x38) Tinned Copper
<b>Insulation</b>	.0075" Nom. Wall Gray PVC
<b>Pitch</b>	.025" ±.002"
<b>Temperature Rating</b>	-40 to +105°C
<b>Flammability Rating</b>	UL: VW-1, CSA: FT1
<b>UL Approval</b>	File #E12683, Style 2678
<b>CSA Approval</b>	File #LL7874, CSA AWM I A 105°C 150V FT1
<b>Packaging</b>	H100, H300

## Electrical Specifications

<b>Voltage Rating</b>	150V RMS
<b>Current Rating</b>	.5A
<b>Conductor Resistance</b>	108Ω/1000 ft.
<b>Insulation Resistance</b>	>1 x 10 <sup>10</sup> Ω • 10 ft. (3m)
<b>Impedance*</b>	70Ω
<b>Capacitance* (@ 1 MHz)</b>	24 pF/ft. (79 pF/m)
<b>Inductance* (@ 1 MHz)</b>	.14 μH/ft. (.46 μH/m)
<b>Propagation Delay*</b>	1.52 ns/ft. (4.96 ns/m)

\*Test Configuration: G-S-G (ground-signal-ground).

Part No.	No. of Cond.	Dimensions			
		Width "A"		Span "B"	
		Inch	mm	Inch	mm
<b>9L30026</b>	26	.650 ±.010	16.51 ±.25	.625 ±.007	15.88 ±.18
<b>9L30050<sup>†</sup></b>	50	1.250 ±.011	31.75 ±.28	1.225 ±.009	31.12 ±.23

<sup>†</sup>Available in H100 packaging only.

## Dimensions

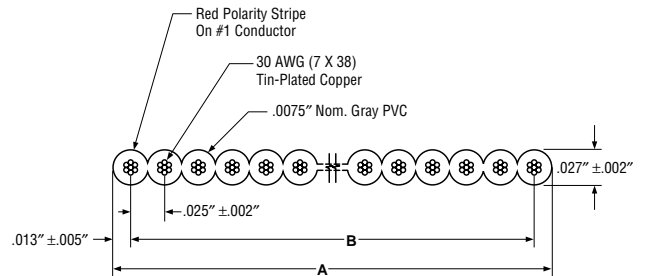

## Unbalanced Crosstalk

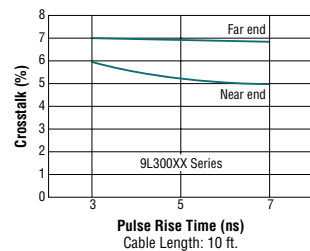

## Attenuation

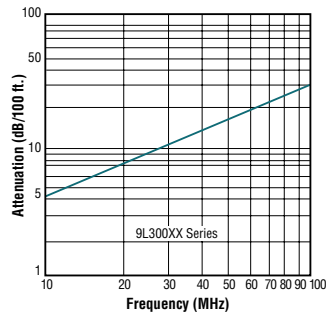

Teflon is a DuPont trademark.



# Gray Ribbon 2L280XX Series

1mm Pitch, 28 AWG, PVC

## Product Description

Belden's 1mm (.03937" pitch) extruded gray ribbon cable was designed for the disk drive market where the 2mm IDC connector is widely used. The cable provides improved space reduction, easy breakouts for circuit routing, and maintains the current carrying capacity required for these applications. In addition, the electrical performance meets those requirements specified by the SCSI-3 parallel interface document. The cable is constructed of stranded 28 AWG (7x36) tinned copper conductors. Insulation material consists of Gray PVC, with a Black polarity stripe for proper circuit alignment. Standard conductor counts are 26, 34, 40, 44 and 50; other sizes are available upon request. The cable is UL approved and CSA certified, and passes the VW-1 Vertical Wire Flame Test.

**Color Code:** Gray with Black polarity stripe.

**Application:** Internal interconnection or internal wiring of electronic equipment.

## Physical Specifications

<b>Conductor</b>	28 AWG (7x36) Tinned Copper
<b>Insulation</b>	.010" Nom. Wall Gray PVC
<b>Pitch</b>	1mm ± 0.51mm (.0394" ± .002")
<b>Temperature Rating</b>	-40 to +105°C
<b>Flammability Rating</b>	UL: VW-1; CSA: FT1
<b>UL Approval</b>	File #E12683, Style 2651
<b>CSA Approval</b>	File #LL7874, CSA AWM I A 105°C 300V FT1
<b>Packaging</b>	H100, R300

## Electrical Specifications

<b>Voltage Rating</b>	300V RMS
<b>Current Rating</b>	1A
<b>Conductor Resistance</b>	68Ω/1000 ft.
<b>Insulation Resistance</b>	>1 x 10 <sup>10</sup> Ω • 10 ft. (3m)
<b>Impedance*</b>	90Ω
<b>Capacitance*</b> (@ 1 MHz)	16.5 pF/ft. (54 pF/m)
<b>Inductance*</b> (@ 1 MHz)	.16 μH/ft. (.52 μH/m)
<b>Propagation Delay*</b>	1.47 ns/ft. (4.8 ns/m)

\*Test Configuration: G-S-G (ground-signal-ground).

Part No.	No. of Cond.	Dimensions			
		Width "A"		Span "B"	
		Inch	mm	Inch	mm
<b>2L28026**</b>	26	1.020 ±.008	25.9 ±.20	.984 ±.008	25.0 ±.20
<b>2L28034**</b>	34	1.335 ±.012	33.9 ±.30	1.299 ±.012	33.0 ±.30
<b>2L28040**</b>	40	1.571 ±.012	39.9 ±.30	1.535 ±.012	39.0 ±.30
<b>2L28044**</b>	44	1.728 ±.012	43.9 ±.30	1.693 ±.012	43.0 ±.30
<b>2L28050</b>	50	1.965 ±.012	49.9 ±.30	1.929 ±.012	49.0 ±.30

\*\*Available in H100 packaging only.

## Dimensions

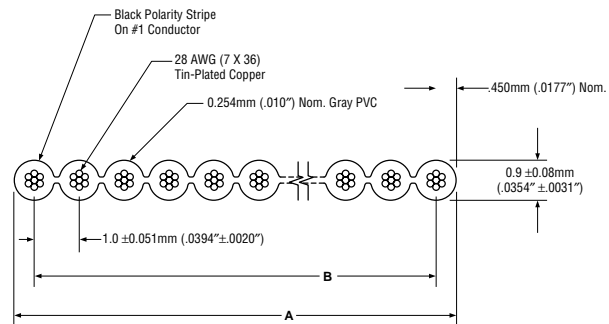

## Unbalanced Crosstalk\*

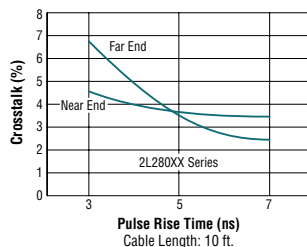

## Attenuation\*

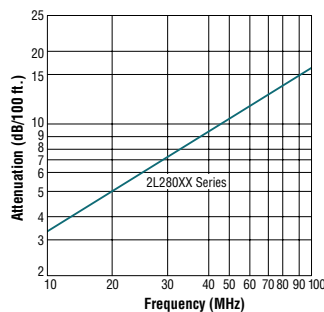

# Gray Ribbon 9L280XX Series

.050" Pitch, 28 AWG, PVC (available in MIL-C-49055/1)

## Product Description

Belden's (9L280XX Series) .050" pitch extruded gray ribbon cable was designed for general purpose electronic interconnect applications. The cable provides reliable mass-termination to standard .100" contact IDC connectors, flexibility, consistent electricals and break-outs can be made easily with the tear feature design. The cable is constructed of stranded 28 AWG (7x36) tinned copper conductors. Insulation material consists of Gray PVC, with a Red polarity stripe for proper circuit alignment. Various conductor counts are standard; other sizes are available upon request. The cable is UL approved and CSA certified, and passes the VW-1 Vertical Wire Flame Test.

**Color Code:** Gray with Red polarity stripe (standard), Gray with Black polarity stripe (MIL-C-49055/1).

**Application:** Internal interconnection or internal wiring of electronic equipment.

## Physical Specifications

<b>Conductor</b>	28 AWG (7x36) Tinned Copper
<b>Insulation</b>	.010" Nom. Wall Gray PVC
<b>Pitch</b>	.050" ±.002"
<b>Temperature Rating</b>	-40 to +105°C
<b>Flammability Rating</b>	UL: VW-1; CSA: FT1
<b>UL Approval</b>	File #E12683, Style 2651
<b>CSA Approval</b>	File #LL7874, CSA AWM I A 105°C 300V FT1
<b>Packaging</b>	H100, H300, R300

## Electrical Specifications

<b>Voltage Rating</b>	300V RMS
<b>Current Rating</b>	1A
<b>Conductor Resistance</b>	68Ω/1000 ft.
<b>Insulation Resistance</b>	>1 x 10 <sup>10</sup> Ω • 10 ft. (3m)
<b>Impedance*</b>	105Ω
<b>Capacitance* (@ 1 MHz)</b>	15 pF/ft. (49 pF/m)
<b>Inductance* (@ 1 MHz)</b>	.20 μH/ft. (.66 μH/m)
<b>Propagation Delay*</b>	1.40 ns/ft. (4.6 ns/m)

\*Test Configuration: G-S-G (ground-signal-ground).

## Unbalanced Crosstalk\*

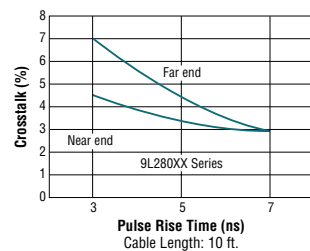

## Attenuation\*

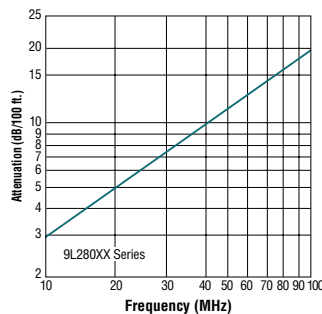

Part No.		No. of Cond.	Dimensions			
Standard (UL & CSA)	MIL-C-49055/1 (QPL) (Designation)		Width "A"		Span "B"	
			Inch	mm	Inch	mm
9L28009	YP-3289 (M49055/1-01)	9	.45 ±.008	11.43 ±.20	.40 ±.008	10.16 ±.20
9L28010	YP-3290 (M49055/1-02)	10	.50 ±.008	12.70 ±.20	.45 ±.008	11.43 ±.20
9L28014†	YP-3291 (M49055/1-03)	14	.70 ±.008	17.78 ±.20	.65 ±.008	16.51 ±.20
9L28015**	YP-3292 (M49055/1-04)	15	.75 ±.008	19.05 ±.20	.70 ±.008	17.78 ±.20
9L28016	YP-3293 (M49055/1-05)	16	.80 ±.008	20.32 ±.20	.75 ±.008	19.05 ±.20
9L28020	YP-3294 (M49055/1-06)	20	1.00 ±.008	25.40 ±.20	.95 ±.008	24.13 ±.20
9L28024†	YP-3295 (M49055/1-07)	24	1.20 ±.008	30.48 ±.20	1.15 ±.008	29.21 ±.20
9L28025	YP-3296 (M49055/1-08)	25	1.25 ±.008	31.75 ±.20	1.20 ±.008	30.48 ±.20
9L28026	YP-3297 (M49055/1-09)	26	1.30 ±.008	33.02 ±.20	1.25 ±.008	31.75 ±.20
9L28034	YP-3298 (M49055/1-10)	34	1.70 ±.008	43.18 ±.20	1.65 ±.008	41.91 ±.20
9L28036**	—	36	1.80 ±.012	45.72 ±.30	1.75 ±.012	44.45 ±.30
9L28037**	YP-3299 (M49055/1-11)	37	1.85 ±.012	46.99 ±.30	1.80 ±.012	45.72 ±.30
9L28040	YP-3300 (M49055/1-12)	40	2.00 ±.012	50.80 ±.30	1.95 ±.012	49.53 ±.30
9L28050	YP-3301 (M49055/1-13)	50	2.50 ±.012	63.50 ±.30	2.45 ±.012	62.23 ±.30
9L28060	YP-3302 (M49055/1-14)	60	3.00 ±.012	76.20 ±.30	2.95 ±.012	74.93 ±.30
9L28064	YP-3303 (M49055/1-15)	64	3.20 ±.012	81.28 ±.30	3.15 ±.012	80.01 ±.30

\*\*Available in H100 packaging only.  
† Not available in R300 packaging.

## Dimensions

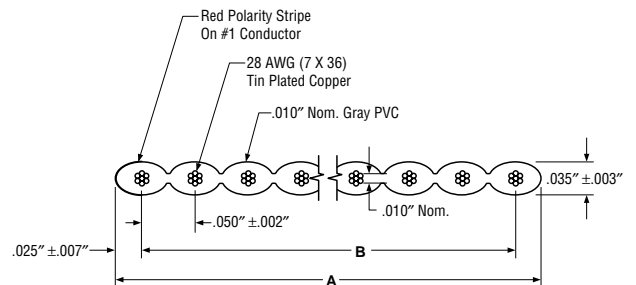

# Gray Ribbon 9L260XX Series

.050" Pitch, 26 AWG, PVC (available in MIL-C-49055/1)

## Product Description

Belden's (9L260XX series) .050" pitch extruded gray ribbon cable was designed for general purpose electronic interconnect applications where higher current carrying capacities are required. The design also conforms to the electrical performance specifications outlined by the SCSI-3 parallel interface document. As with the 9L280XX series, the cable provides reliable mass-termination to standard .100" contact IDC connectors, flexibility, consistent electricals and breakouts can be made easily with the tear feature design. In addition, the overall cable thickness is only .038" ± .002" allowing mateability with all standard IDC connectors. The cable is constructed of stranded 26 AWG (7x34) tinned copper conductors. Insulation material consists of Gray PVC, with a Blue polarity stripe for proper circuit alignment. Various conductor counts are standard; other sizes are available upon request. The cable is UL approved and CSA certified, and passes the VW-1 Vertical Wire Flame Test.

**Color Code:** Gray with Blue polarity stripe (standard), Gray with Black polarity stripe (MIL-C-49055/1).

**Application:** Internal interconnection or internal wiring of electronic equipment.

## Physical Specifications

<b>Conductor</b>	26 AWG (7x34) Tinned Copper
<b>Insulation</b>	.010" Nom. Wall Gray PVC
<b>Pitch</b>	.050" ± .002"
<b>Temperature Rating</b>	-40 to +105°C
<b>Flammability Rating</b>	UL: VW-1; CSA: FT1
<b>UL Approval</b>	File #E12683, Style 2651
<b>CSA Approval</b>	File #LL7874, CSA AWM I A 105°C 300V FT1
<b>Packaging</b>	H100, H300, R300

## Electrical Specifications

<b>Voltage Rating</b>	300V RMS
<b>Current Rating</b>	1.5A
<b>Conductor Resistance</b>	43Ω/1000 ft.
<b>Insulation Resistance</b>	>1 x 10 <sup>10</sup> Ω • 10 ft. (3m)
<b>Impedance*</b>	90Ω
<b>Capacitance* (@ 1 MHz)</b>	18 pF/ft. (55 μH/m)
<b>Inductance* (@ 1 MHz)</b>	.15 μH/ft. (.49 μH/m)
<b>Propagation Delay*</b>	1.48 ns/ft. (4.85 ns/m)

\*Test Configuration: G-S-G (ground-signal-ground).

Part No.		No. of Cond.	Dimensions			
Standard [UL & CSA]	MIL-C-49055/1 [QPL] (Designation)		Width "A"		Span "B"	
			Inch	mm	Inch	mm
9L26010	YP-3305 (M49055/1-17)	10	.50 ±.008	12.70 ±.20	.45 ±.008	11.43 ±.20
9L26014††	YP-3306 (M49055/1-18)	14	.70 ±.008	17.78 ±.20	.65 ±.008	16.51 ±.20
9L26016**	YP-3308 (M49055/1-20)	16	.80 ±.008	20.32 ±.20	.75 ±.008	19.05 ±.20
9L26020††	YP-3309 (M49055/1-21)	20	1.0 ±.008	25.40 ±.20	.95 ±.008	24.13 ±.20
9L26025**	YP-3311 (M49055/1-23)	25	1.25 ±.008	31.75 ±.20	1.20 ±.008	30.48 ±.20
9L26026††	YP-3312 (M49055/1-24)	26	1.30 ±.008	33.02 ±.20	1.25 ±.008	31.75 ±.20
9L26034**	YP-3313 (M49055/1-25)	34	1.70 ±.008	43.18 ±.20	1.65 ±.008	41.91 ±.20
9L26040†	YP-3315 (M49055/1-27)	40	2.00 ±.012	50.80 ±.30	1.95 ±.012	49.53 ±.30
9L26044**	—	44	2.20 ±.012	55.88 ±.30	2.15 ±.012	54.61 ±.30
9L26068**	—	68	3.40 ±.012	86.36 ±.30	3.35 ±.012	85.09 ±.30

\*\* Available in H100 packaging only.  
 † Not available in H300 packaging.  
 †† Not available in R300 packaging.

## Dimensions

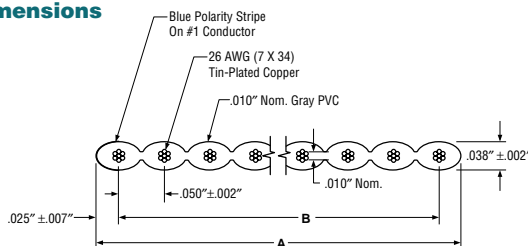

## Unbalanced Crosstalk\*

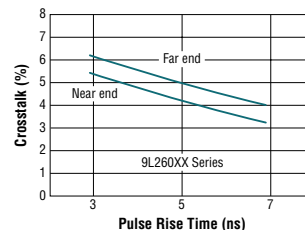

## Attenuation\*

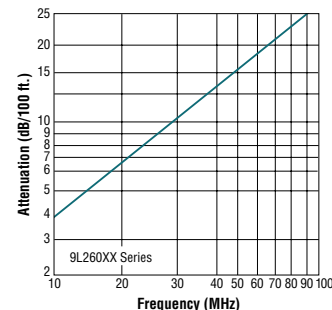

# Rainbow 9R280XX Series

.050" Pitch, 28 AWG, Color-coded PVC

## Product Description

Belden's .050" pitch, color-coded PVC flat cable allows for quick identification and circuit tracing, along with easy breakouts for circuit routing. Designed for mass-termination with standard IDC connectors. The cable is constructed of stranded 28 AWG (7x36) tinned copper conductors, color-coded PVC preinsulated singles — laminated to a single clear PVC substrate. Fourteen various conductor counts are standard; other sizes are available upon request. The cable is UL approved (CSA available upon request) and passes the VW-1 Vertical Wire Flame Test.

**Color Code:** Brown, Red, Orange, Yellow, Green, Blue, Violet, Gray, White, Black. Sequence is repeated as necessary.

**Application:** Internal interconnection or internal wiring of electrical equipment.

## Physical Specifications

<b>Conductor</b>	28 AWG (7x36) Tinned Copper
<b>Insulation</b>	.010" Nom. Wall Color-coded PVC
<b>Substrate</b>	.010" Nom. Wall Clear PVC
<b>Pitch</b>	.050" ±.005"
<b>Temperature Rating</b>	-20 to +105°C
<b>Flammability Rating</b>	UL: VW-1
<b>UL Approval</b>	File #E12663, Style 2884
<b>CSA Approval</b>	Available upon request
<b>Packaging</b>	100

## Electrical Specifications

<b>Voltage Rating</b>	300V RMS
<b>Current Rating</b>	1A
<b>Conductor Resistance</b>	68Ω/1000 ft.
<b>Insulation Resistance</b>	>1 x 10 <sup>10</sup> Ω • 10 ft. (3m)
<b>Impedance*</b>	105Ω
<b>Capacitance* (@ 1 MHz)</b>	15 pF/ft. (49 pF/m)
<b>Inductance* (@ 1 MHz)</b>	.20 μH/ft. (.66 μH/m)
<b>Propagation Delay*</b>	1.4 ns/ft. (4.6 ns/m)

\*Test Configuration: G-S-G (ground-signal-ground).

## Unbalanced Crosstalk\*

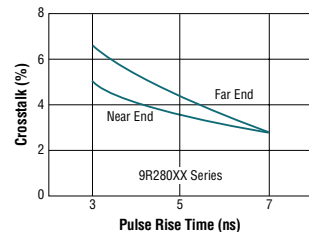

## Attenuation\*

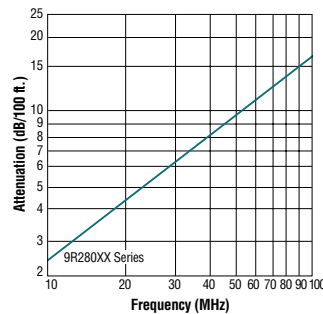

Part No.	No. of Cond.	Dimensions			
		Width "A"		Span "B"	
		Inch	mm	Inch	mm
9R28010	10	.50	12.70	.45 ±.007	11.43 ±.18
9R28014	14	.70	17.78	.65 ±.007	16.51 ±.18
9R28016	16	.80	20.32	.75 ±.011	19.50 ±.28
9R28020	20	1.00	25.40	.95 ±.011	24.13 ±.28
9R28024	24	1.20	30.48	1.15 ±.011	29.21 ±.28
9R28025	25	1.25	31.75	1.20 ±.011	30.48 ±.28
9R28026	26	1.30	33.02	1.25 ±.011	31.75 ±.28
9R28034	34	1.70	43.18	1.65 ±.011	41.91 ±.28
9R28036	36	1.80	45.72	1.75 ±.015	44.45 ±.38
9R28037	37	1.85	46.99	1.80 ±.015	45.72 ±.38
9R28040	40	2.00	50.80	1.95 ±.015	49.53 ±.38
9R28050	50	2.50	63.50	2.45 ±.015	62.23 ±.38
9R28060	60	3.00	76.20	2.95 ±.015	74.93 ±.38
9R28064	64	3.20	81.28	3.15 ±.020	80.01 ±.51

## Dimensions

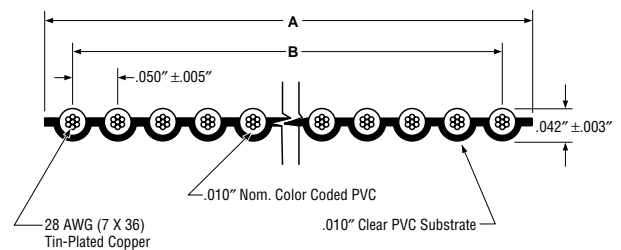

# Rainbow 8R280XX Series

.050" Pitch, 28 AWG, Color-coded FEP (High Temperature)

## Product Description

Belden's .050" pitch, color-coded FEP flat cable allows for high and low temperature, low out-gassing and chemical resistant applications, improved electricals, and provides quick identification and circuit tracing, along with easy breakouts for circuit routing. Designed for mass-termination with standard IDC connectors, the cable is constructed of stranded 28 AWG (7x36) silver-plated copper conductors, color-coded FEP pre-insulated singles — laminated to a single clear FEP substrate. Thirteen various conductor counts are standard; other sizes are available upon request. The cable is UL approved and passes the IEEE 383, 70,000 BTU Flame Test.

**Color Code:** Brown, Red, Orange, Yellow, Green, Blue, Violet, Gray, White, Black. Sequence is repeated as necessary.

**Application:** Internal wiring of appliances or electronic equipment. May be additionally marked "For 300V Peak Electronic Use Only."

## Physical Specifications

<b>Conductor</b>	28 AWG (7x36) Silver-plated Copper
<b>Insulation</b>	.010" Nom. Wall Color-coded FEP
<b>Substrate</b>	.010" Nom. Wall Clear FEP
<b>Pitch</b>	.050" ±.005"
<b>Temperature Rating</b>	-70 to +150°C
<b>Flammability Rating</b>	UL: VW-1; IEEE: 383 70,000 BTU
<b>UL Approval</b>	File #E12683, Style 20468
<b>Packaging</b>	100

## Electrical Specifications

<b>Voltage Rating</b>	150V RMS
<b>Current Rating</b>	1A
<b>Conductor Resistance</b>	68Ω/1000 ft.
<b>Insulation Resistance</b>	>1 x 10 <sup>11</sup> Ω • 10 ft. (3m)
<b>Impedance*</b>	120Ω
<b>Capacitance*</b> (@ 1 MHz)	10.5 pF/ft. (34.4 pF/m)
<b>Inductance*</b> (@ 1 MHz)	.18 μH/ft. (.59 μH/m)
<b>Propagation Delay*</b>	1.3 ns/ft. (4.3 ns/m)

\*Test Configuration: G-S-G (ground-signal-ground).

Part No.	No. of Cond.	Dimensions			
		Width "A"		Span "B"	
		Inch	mm	Inch	mm
<b>8R28010</b>	10	.50	12.70	.45 ±.007	11.43 ±.18
<b>8R28014</b>	14	.70	17.78	.65 ±.007	16.51 ±.18
<b>8R28016</b>	16	.80	20.32	.75 ±.011	19.05 ±.28
<b>8R28020</b>	20	1.00	25.40	.95 ±.011	24.13 ±.28
<b>8R28025</b>	25	1.25	31.75	1.20 ±.011	30.48 ±.28
<b>8R28026</b>	26	1.30	33.02	1.25 ±.011	31.75 ±.28
<b>8R28034</b>	34	1.70	43.18	1.65 ±.011	41.91 ±.28
<b>8R28036</b>	36	1.80	45.72	1.75 ±.015	44.45 ±.38
<b>8R28037</b>	37	1.85	46.99	1.80 ±.015	45.72 ±.38
<b>8R28040</b>	40	2.00	50.80	1.95 ±.015	49.53 ±.38
<b>8R28050</b>	50	2.50	63.50	2.45 ±.015	62.23 ±.38
<b>8R28060</b>	60	3.00	76.20	2.95 ±.015	74.93 ±.38
<b>8R28064</b>	64	3.20	81.28	3.15 ±.020	80.01 ±.51

## Dimensions

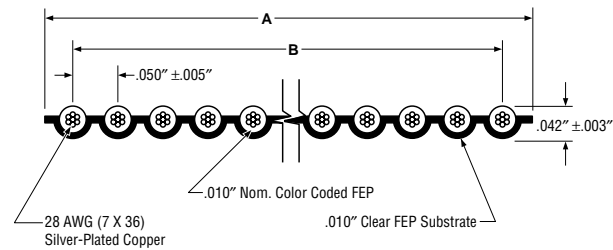

## Unbalanced Crosstalk\*

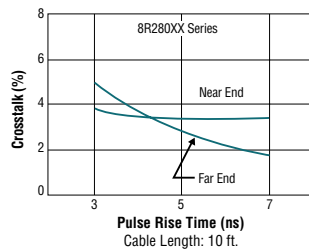

## Attenuation\*

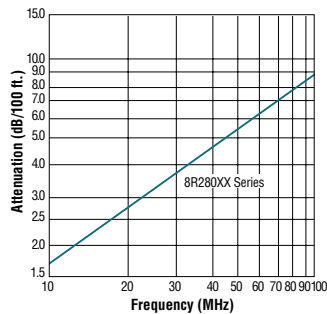



# Vari-Twist® 9V280XX Series

.050" Pitch, 28 AWG, PVC

## Product Description

Belden's PVC Vari-Twist 9V280XX series was designed to reduce crosstalk in the balanced mode by twisting the pairs, but can be mass-terminated in the programmed flat sections with any standard IDC connector. To further reduce crosstalk, each adjacent pair is twisted in the opposite direction. The standard twist length is 18 inches followed by a 2 inch flat section of .050" spaced conductors. The cable consists of stranded 28 AWG (7x36) tinned copper, color-coded PVC preinsulated singles — laminated to a single clear PVC substrate. Eleven various conductor/pair counts are standard; other sizes are available upon request. The cable is UL approved (CSA available upon request) and passes the VW-1 Vertical Wire Flame Test.

Upon your request, Vari-Twist can also be manufactured to your own specific requirements whether that be longer or shorter twist sections and/or flat sections.

**Color Code:** Each pair consists of a Tan conductor paired with a color-coded conductor. *Color Sequence Each Terminating Section:* Brown/Tan, Red/Tan, Orange/Tan, Yellow/Tan, Green/Tan, Blue/Tan, Violet/Tan, Gray/Tan, White/Tan, Black/Tan. Sequence is repeated as necessary.

**Application:** Internal interconnection or internal wiring of electronic equipment.

## Physical Specifications

<b>Conductor</b>	28 AWG (7x36) Tinned Copper
<b>Insulation</b>	.010" Nom. Wall Color-coded PVC
<b>Substrate</b>	.010" Nom. Wall Clear PVC
<b>Pitch</b>	
Twisted Pair Centers:	.100" Nom.
Conductor Centers in Flat:	.050" ±.005"
<b>Pairs</b>	1/2" Nom. Lay
	Adjacent Pairs have Opposite Direction Lay
<b>Construction</b>	18" of Twisted Pairs
	2" of Flat Section
<b>Temperature Rating</b>	-20 to +105°C
<b>Flammability Rating</b>	UL: VW-1
<b>UL Approval</b>	File #E12683, Style Dual Rated 2693 & 2697
<b>CSA Approval</b>	Available Upon Request
<b>Packaging</b>	H100

## Electrical Specifications

<b>Voltage Rating</b>	300V RMS
<b>Current Rating</b>	1A
<b>Conductor Resistance</b>	68Ω/1000 ft.
<b>Insulation Resistance</b>	>1 x 10 <sup>10</sup> Ω • 10 ft. (3m)
<b>Impedance (Balanced)</b>	115Ω
<b>Impedance* (Unbalanced)</b>	100Ω
<b>Capacitance* (@ 1 MHz)</b>	16 pF/ft. (52 pF/m)
<b>Inductance* (@ 1 MHz)</b>	.24 μH/ft. (.79 μH/m)
<b>Propagation Delay*</b>	1.6 ns/ft. (5.25 ns/m)

\*Test Configuration: G-S (ground-signal), unbalanced.

Part No.	No. of Pairs	Dimensions			
		Width "A"		Span "B"	
		Inch	mm	Inch	mm
9V28010	5	.50	12.70	.45 ±.012	11.43 ±.30
9V28014	7	.70	17.78	.65 ±.012	16.51 ±.30
9V28016	8	.80	20.32	.75 ±.012	19.05 ±.30
9V28020	10	1.00	25.40	.95 ±.015	24.13 ±.38
9V28026	13	1.30	33.02	1.25 ±.015	31.75 ±.38
9V28034	17	1.70	43.18	1.65 ±.015	41.91 ±.38
9V28036	18	1.80	45.72	1.75 ±.017	44.45 ±.43
9V28040	20	2.00	50.80	1.95 ±.017	49.53 ±.43
9V28050	25	2.50	63.50	2.45 ±.017	62.23 ±.43
9V28060	30	3.00	76.20	2.95 ±.020	74.93 ±.51
9V28064	32	3.20	81.28	3.15 ±.020	80.01 ±.51

## Dimensions

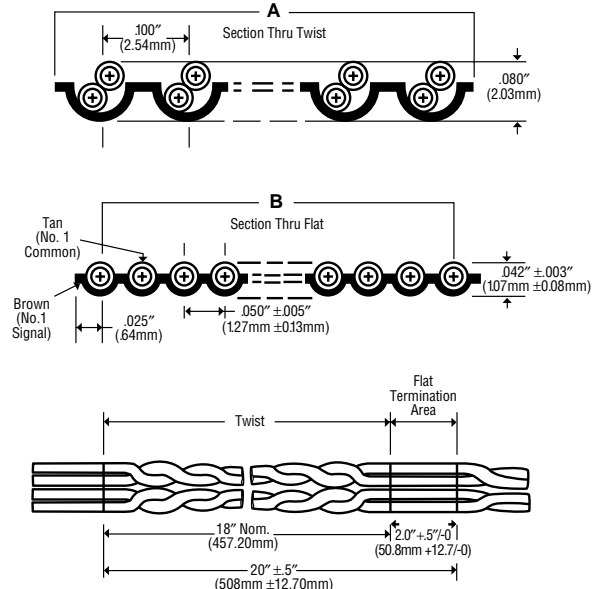

NOTE: the transition area is included in the twisted section to assure a full 2 inches of .050" termination area.

## Unbalanced Crosstalk\*

(See page 7.14 for Balanced Crosstalk)

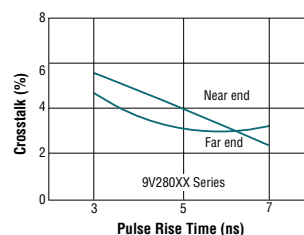

## Attenuation\*

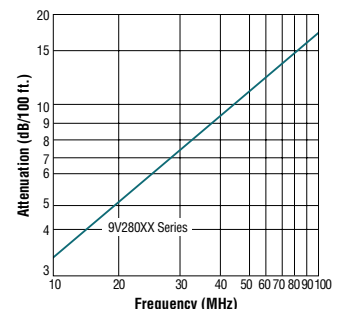

# Vari-Twist® 8V280XX Series

.050" Pitch, 28 AWG, FEP (High Temperature)

## Product Description

Belden's FEP Vari-Twist 8V280XX series allows for high and low temperature, low out-gassing, and chemical resistant applications, improved electricals, and provides quick identification and circuit tracing. The cable was designed to reduce crosstalk in the balanced mode by twisting the pairs but can be mass-terminated in the programmed flat sections with any standard IDC connector. To further reduce crosstalk, each adjacent pair is twisted in the opposite direction. The standard twist length is 18 inches followed by a 2 inch flat section of .050" spaced conductors. The cable consists of stranded 28 AWG (7x36) silver-plated copper, color-coded FEP preinsulated singles — laminated to a single clear FEP substrate. Eight various conductor/pair counts are standard; other sizes are available upon request. The cable is UL approved and passes the IEEE 383 70,000 BTU Flame Test.

Upon your request, Vari-Twist can also be manufactured to your own specific requirements whether that be longer or shorter twist sections and/or flat sections.

**Color Code:** Each pair consists of a Tan conductor paired with a color-coded conductor. *Color Sequence Each Terminating Section:* Brown/Tan, Red/Tan, Orange/Tan, Yellow/Tan, Green/Tan, Blue/Tan, Violet/Tan, Gray/Tan, White/Tan, Black/Tan. Sequence is repeated as necessary.

**Application:** Internal wiring of appliances or electronic equipment. May be additionally marked "For 300V Peak Electronic Use Only."

## Physical Specifications

<b>Conductor</b>	28 AWG (7x36) Silver-plated Copper
<b>Insulation</b>	.010" Nom. Wall Color-coded FEP
<b>Substrate</b>	.010" Nom. Wall Clear FEP
<b>Pitch</b>	
Twisted Pair Centers:	.100" Nom.
Conductor Centers in Flat:	.050" ±.005"
<b>Pairs</b>	1/2" Nom. Lay
	Adjacent Pairs have Opposite Direction Lay
<b>Construction</b>	18" of Twisted Pairs
	2" of Flat Section
<b>Temperature Rating</b>	-70 to +150°C
<b>Flammability Rating</b>	UL: VW-1; IEEE 383 70,000 BTU
<b>UL Approval</b>	File #E12683, Style 20468
<b>Packaging</b>	100

## Electrical Specifications

<b>Voltage Rating</b>	150V RMS
<b>Current Rating</b>	1A
<b>Conductor Resistance</b>	68Ω/1000 ft.
<b>Insulation Resistance</b>	>1 x 10 <sup>11</sup> Ω • 10 ft. (3m)
<b>Impedance (Balanced)</b>	145Ω
<b>Impedance* (Unbalanced)</b>	130Ω
<b>Capacitance* (@ 1 MHz)</b>	10.6 pF/ft. (34.78 pF/m)
<b>Inductance* (@ 1 MHz)</b>	.22 μH/ft. (.72 μH/m)
<b>Propagation Delay*</b>	1.32 ns/ft. (4.33 ns/m)

\*Test Configuration: G-S (ground-signal), unbalanced.

Part No.	No. of Pairs	Dimensions			
		Width "A"		Span "B"	
		Inch	mm	Inch	mm
<b>8V28010</b>	5	.50	12.70	.45 ±.012	11.43 ±.30
<b>8V28014</b>	7	.70	17.78	.65 ±.012	16.51 ±.30
<b>8V28020</b>	10	1.00	25.40	.95 ±.015	24.13 ±.38
<b>8V28026</b>	13	1.30	33.02	1.25 ±.015	31.75 ±.38
<b>8V28034</b>	17	1.70	43.18	1.65 ±.015	41.91 ±.38
<b>8V28036</b>	18	1.80	45.72	1.75 ±.017	44.45 ±.43
<b>8V28040</b>	20	2.00	50.80	1.95 ±.017	49.53 ±.43
<b>8V28060</b>	30	3.00	76.20	2.95 ±.020	74.93 ±.51

## Dimensions

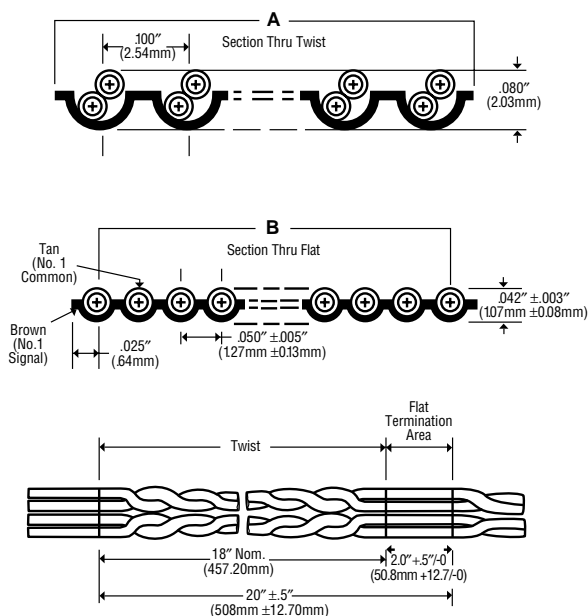

NOTE: the transition area is included in the twisted section to assure a full 2 inches of .050" termination area.

## Unbalanced Crosstalk\*

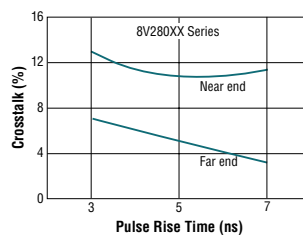

## Attenuation\*

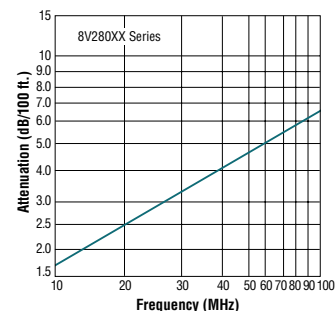

# Shielded Jacketed 9L283XX Series

.050" Pitch, 28 AWG, PVC

## Product Description

Belden's shielded jacketed 9L283XX series was designed to help meet the FCC EMI/RFI requirements. In addition, the cable provides shielding from external electrical interference along with excellent crosstalk attenuation. The thin extruded jacket allows for greater flexibility, ease of termination, and reduced space requirements, while providing exterior protection from the environment. The core cable is Belden's 9L280XX PVC series allowing easy termination to any standard IDC connector. All cables are 100% shielded with a Duofoil® shield (aluminum/polyester/aluminum) and can be terminated with the two 28 AWG drain wires. Thirteen various conductor counts are standard; other sizes are available upon request. The cable is UL approved and CSA certified, and passes the VW-1 Vertical Wire Flame Test.

**Color Code:** Gray with Red polarity stripe.

**Application:** External interconnection or internal wiring of electronic equipment.

## Physical Specifications

<b>Conductor</b>	28 AWG (7x36) Tinned Copper
<b>Insulation</b>	.010" Nom. Wall Gray PVC
<b>Pitch</b>	.050" ±.002"
<b>Shielding</b>	Duofoil Shield (Aluminum/Polyester/Aluminum)
<b>Drain Wires</b>	Two 28 AWG (7x36) Tinned Copper
<b>Jacket</b>	.038" Nom. Wall Black PVC
<b>Temperature Rating</b>	-20 to +105°C
<b>Flammability Rating</b>	UL: VW-1; CSA: FT1
<b>UL Approval</b>	File #E12683, Style 20081
<b>CSA Approval</b>	File #LL7874, CSA AWM II A 105°C 300V FT1
<b>Packaging</b>	100

## Electrical Specifications

<b>Voltage Rating</b>	300V RMS
<b>Current Rating</b>	1A
<b>Conductor Resistance</b>	68Ω/1000 ft.
<b>Insulation Resistance</b>	>1 x 10 <sup>10</sup> Ω • 10 ft. (3m)
<b>Impedance*</b>	45Ω
<b>Capacitance* (@ 1 MHz)</b>	50 pF/ft. (164 pF/m)
<b>Inductance* (@ 1 MHz)</b>	.11 μH/ft. (.36 μH/m)
<b>Propagation Delay*</b>	1.70 ns/ft. (5.6 ns/m)

\*Test Configuration: G-S-G (ground-signal-ground), with shield grounded.

Part No.	No. of Cond.	Dimensions			
		Width "A"		Span "B"	
		Inch	mm	Inch	mm
9L28309	9	.55	13.97	.40 ±.008	10.16 ±.20
9L28310	10	.60	15.24	.45 ±.008	11.43 ±.20
9L28315	15	.85	21.59	.70 ±.008	17.78 ±.20
9L28320	20	1.10	27.94	.95 ±.008	24.13 ±.20
9L28325	25	1.35	34.29	1.20 ±.008	30.48 ±.20
9L28326	26	1.40	35.56	1.25 ±.008	31.75 ±.20
9L28334	34	1.80	45.72	1.65 ±.008	41.91 ±.20
9L28336	36	1.90	48.26	1.75 ±.012	44.45 ±.30
9L28337	37	1.95	49.53	1.80 ±.012	45.72 ±.30
9L28340	40	2.10	53.34	1.95 ±.012	49.53 ±.30
9L28350	50	2.60	66.04	2.45 ±.012	62.23 ±.30
9L28360	60	3.10	78.74	2.95 ±.012	74.93 ±.30
9L28364	64	3.30	83.82	3.15 ±.012	80.01 ±.30

## Dimensions

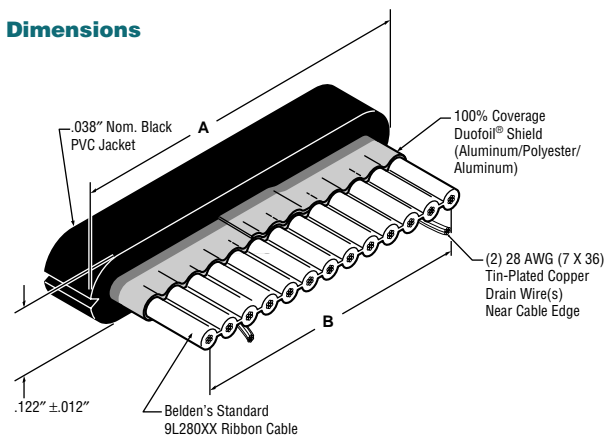

## Unbalanced Crosstalk\*

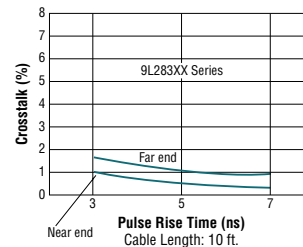

## Attenuation\*

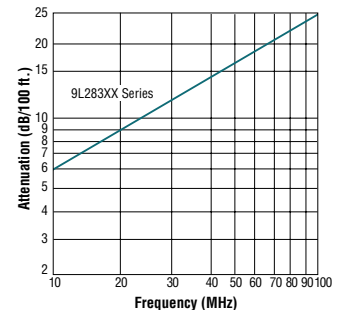

# Shielded Jacketed Vari-Twist® 9V283XX Series

.050" Pitch, 28 AWG, PVC

## Product Description

Belden's shielded jacketed 9V283XX series was designed to help meet the FCC EMI/RFI requirements. In addition, the cable provides shielding from external electrical interference along with excellent crosstalk attenuation. As with the 9V280XX series, the cable supplies the electrical benefits of twisted pairs, but can be mass-terminated in the programmed flat sections. The thin extruded jacket allows for greater flexibility, ease of termination, reduced space requirements, and identification of the flat sections while providing exterior protection from the environment. The core cable is Belden's 9V280XX PVC series to allow easy termination to any standard IDC connector. All cables are 100% shielded with a Duofoil® shield (aluminum/polyester/aluminum) and can be terminated with the two 28 AWG drain wires. Ten various conductor/pair counts are standard; other sizes are available upon request. The cable is UL approved (CSA available upon request) and passes the VW-1 Vertical Wire Flame Test.

**Color Code:** Brown, Red, Orange, Yellow, Green, Blue, Violet, Gray, White, Black, with common Tan. Repeat.

**Application:** External interconnection or internal wiring of electronic equipment.

## Physical Specifications

<b>Conductor</b>	28 AWG (7x36) Tinned Copper
<b>Insulation</b>	.010" Nom. Wall Color-coded PVC
<b>Substrate</b>	.010" Nom. Wall Clear PVC
<b>Pitch</b>	
Twisted Pair Centers:	.100" Nom.
Conductor Centers in Flat:	.050" ±.005"
<b>Pairs</b>	1/2" Nom. Lay
	Adjacent Pairs have Opposite Direction Lay
<b>Construction</b>	18" of Twisted Pairs 2" of Flat Section
<b>Shielding</b>	Duofoil Shield (Aluminum/Polyester/Aluminum)
<b>Drain Wires</b>	Two 28 AWG (7x36) Tinned Copper
<b>Jacket</b>	.038" Nom. Wall Black PVC
<b>Temperature Rating</b>	-20 to +105°C
<b>Flammability Rating</b>	UL: VW-1
<b>UL Approval</b>	File #E12683, Style 20081
<b>CSA Approval</b>	Available Upon Request
<b>Packaging</b>	100

## Electrical Specifications

<b>Voltage Rating</b>	300V RMS
<b>Current Rating</b>	1A
<b>Conductor Resistance</b>	68Ω/1000 ft.
<b>Insulation Resistance</b>	>1 x 10 <sup>10</sup> Ω • 10 ft. (3m)
<b>Impedance (Balanced)</b>	100Ω
<b>Impedance* (Unbalanced)</b>	60Ω
<b>Capacitance* (@ 1 MHz)</b>	29 pF/ft. (95 pF/m)
<b>Inductance* (@ 1 MHz)</b>	.13 μH/ft. (.43 μH/m)
<b>Propagation Delay*</b>	1.6 ns/ft. (5.25 ns/m)

\*Test Configuration: G-S-G (ground-signal-ground) with shield grounded.

Part No.	No. of Pairs	Dimensions			
		Width "A"		Span "B"	
		Inch	mm	Inch	mm
9V28310	5	.60	15.24	.45 ±.012	11.43 ±.30
9V28314	7	.80	20.32	.65 ±.012	16.51 ±.30
9V28316	8	.90	22.86	.75 ±.012	19.05 ±.30
9V28320	10	1.10	27.94	.95 ±.015	24.13 ±.38
9V28326	13	1.40	35.56	1.25 ±.015	31.75 ±.38
9V28334	17	1.80	45.72	1.65 ±.015	41.91 ±.38
9V28336	18	1.90	48.26	1.75 ±.017	44.45 ±.43
9V28340	20	2.10	53.34	1.95 ±.017	49.53 ±.43
9V28350	25	2.60	66.04	2.45 ±.017	62.23 ±.43
9V28360	30	3.10	78.74	2.95 ±.020	74.93 ±.51

## Dimensions

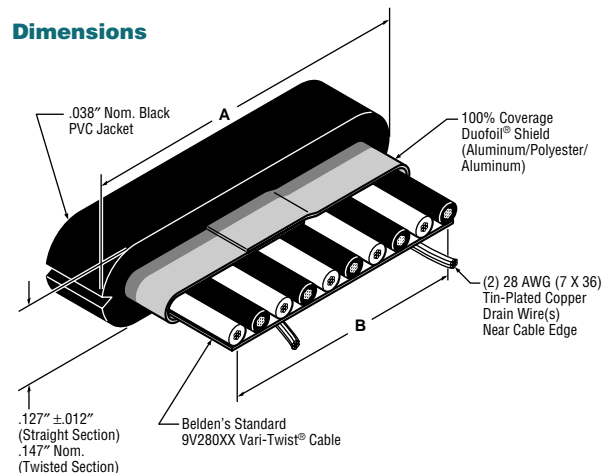

## Unbalanced Crosstalk\*

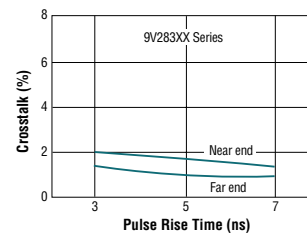

## Attenuation\*

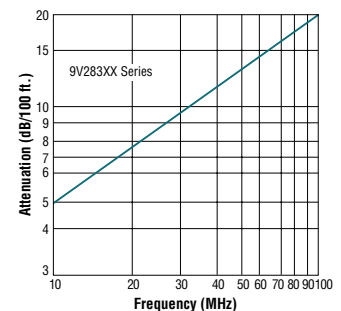

## Technical Information

### Flat Cable Crosstalk Testing

The following is a description of two methods Belden uses to test its flat cable for crosstalk. Because these methods are different, the results may be different even when the same type of cable is used in each test. In short, the reader is offered two different tests to determine which cable type has the best crosstalk characteristics. At times, the results of these two test methods do not agree. Therefore, it is best for the reader to determine which method most closely approximates actual cable application and use its results for cable comparisons.

#### Unbalanced Crosstalk

The unbalanced crosstalk of flat cables is measured as shown in Figure 1. One end of the cable drive is connected through an impedance matching device to a signal generator. The other end of the drive line is terminated in its characteristic impedance. The signal generator is capable of generating square wave pulses of varying leading edge rise times.

A test signal from the signal generator is inserted into the drive line. The cable is connected as follows: Ground-Drive line-Ground-Sample line-Ground or GSG mode. The sample line is also terminated at both ends in its characteristic impedance. The signal at each end of the sample line is measured. The signal at the signal generator end of the sample line is called the near end or reverse crosstalk. The signal at the opposite end of the sample line is called the far end or forward crosstalk. The actual crosstalk figures are given in % and are calculated as follows:

$$\% \text{ Crosstalk} = \frac{\text{Signal in sample line}}{\text{Signal in drive line}} \times 100\%$$

This type of crosstalk test is widely accepted in the flat cable industry. It is a very good method to determine the pulse crosstalk of all types of flat cables connected in the GSG mode. Crosstalk data for Belden flat cables tested using this method is given in the electrical data section of each cable.

Figure 1: Unbalanced Near End Crosstalk

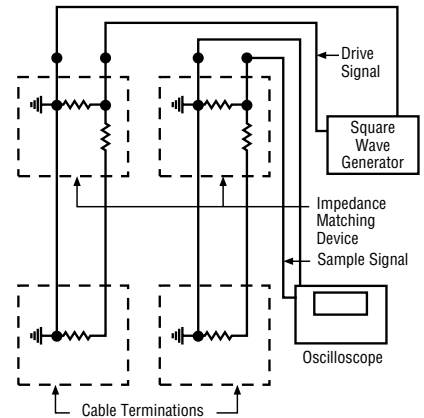

# Technical Information

## Flat Cable Crosstalk Testing

### Balanced Crosstalk

Twisted pair flat cables are not designed to be connected in the GSG mode. These cables provide positive crosstalk reduction over non-twisted pair cables when used in the balanced mode. The balanced crosstalk of twisted pair flat cables is measured as shown in Figure 2. One end of the cable drive pair is connected through a balanced impedance matching transformer to the network analyzer input. The other end of the cable drive pair is terminated in its characteristic impedance. One end of the cable sample pair is terminated in its characteristic impedance. The other end of the cable sample pair is connected through a balanced impedance matching transformer to the network analyzer output. Because impedance matching transformers are used, none of the wires in the drive or sample line share a common ground. The signal in each line is balanced to ground. For example, one wire of the line will carry the inverse of the signal in the other wire in the same line at any given moment. The signal from the tracking generator is a range of frequencies, typically from 10 MHz to 100 MHz. The signal at each end of the sample line is measured in units of dB of isolation using a spectrum analyzer. The crosstalk results of two cables, one with parallel non-twisted conductors (9L Series) and the other with twisted pair conductors (9V Series) is shown in Figure 3.

In conclusion, it is not the intent of this section to recommend one type of crosstalk testing over another. Rather, it is intended to demonstrate there are different cable types for the different cable applications.

Please choose the crosstalk testing method which most closely approximates your application.

Figure 2: Balanced Near End Crosstalk

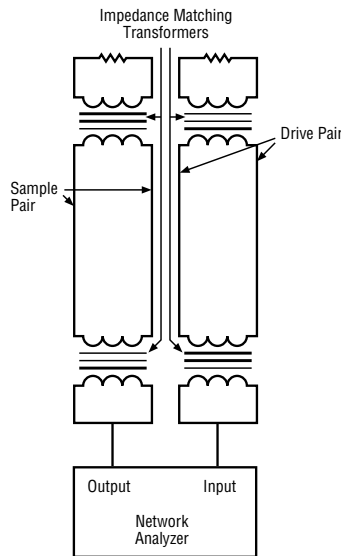

Figure 3: Balanced Crosstalk

